

Outline of the SPICA system

H. Murakami, and SPICA Pre-project Team

Which rocket ?

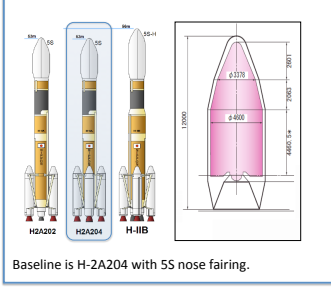

How heavy is SPICA ?

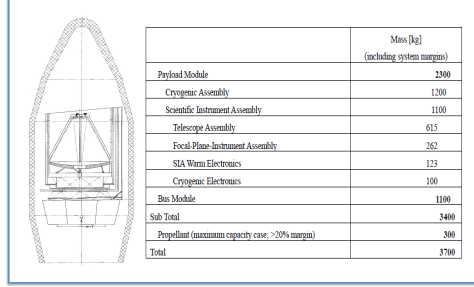

What orbit ?

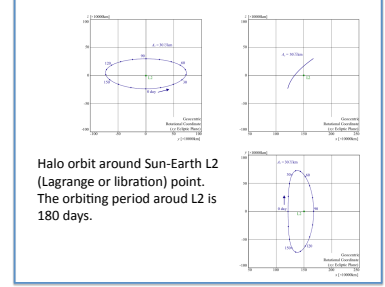

How about configuration of SPICA ?

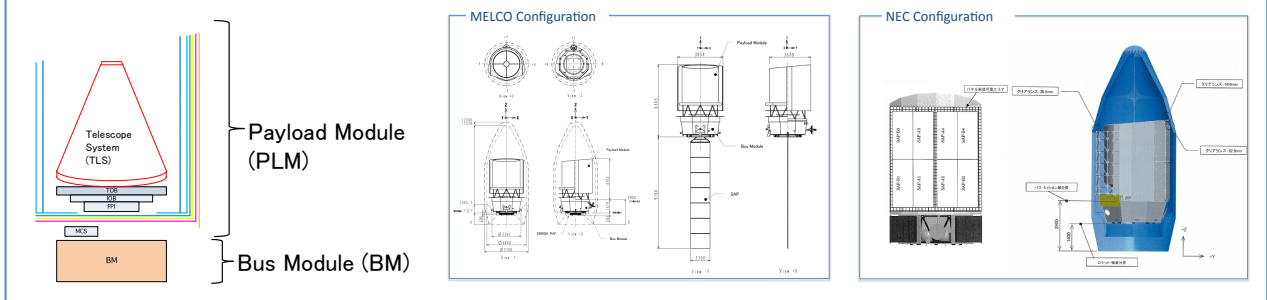

How cool the telescope and focal-plane-instruments ?

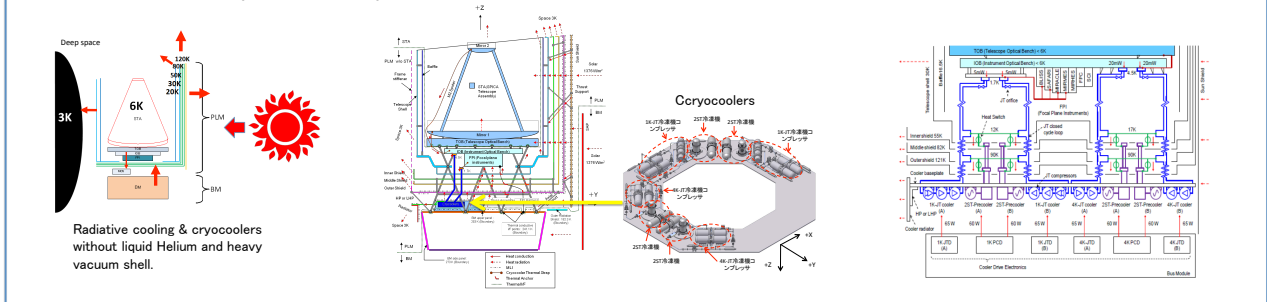

How accurate is telescope pointing ?

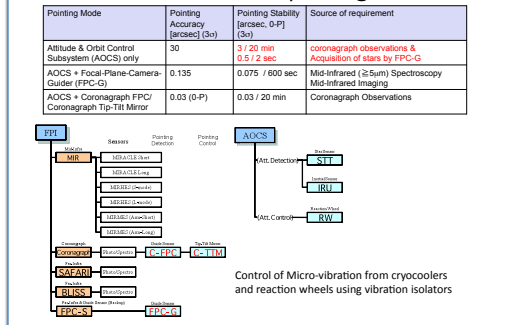

How fast is data downlink & data handling?

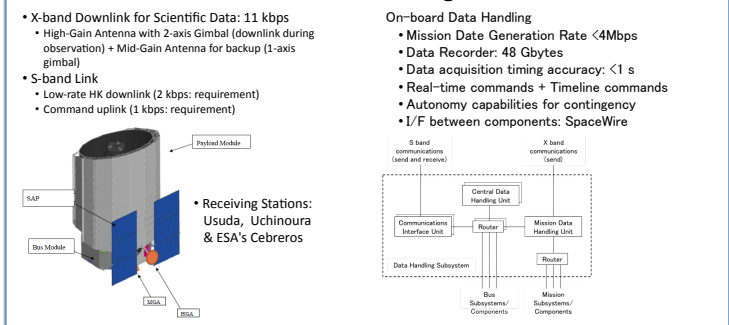

How about Power Supply?

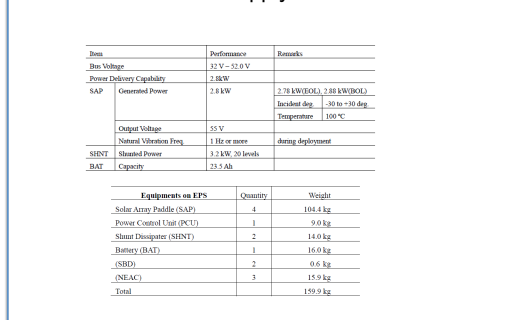

How about thruster system?

